

AHT 
a member of **DAIKIN** group

FIXWELL
www.fixwell.co.nz



BOSTON

_Chest freezer. Full Plug-in

Strong in Design, strong in functionality

BOSTON is accessible from all sides and easily visible. The strong design and total flexibility makes it the perfect freezer for selling scooping ice cream.



VISUAL MERCHANDISE

BOSTON combines attractive product presentation with optimal product visibility from all sides. This ensures high sales attractiveness.



LOW COSTS

The low investment and operating costs speak for themselves. In addition, BOSTON is completely maintenance-free in terms of refrigeration technology.



HIGH ENERGY SAVINGS

Save money with the sophisticated technology and construction compared to conventional ice cream display cases. Greater efficiency is achieved above all by the new energy-saving fan, which saves 0.5 kWh of energy per day.



SMART INSTALLATION

Thanks to the plug-in installation, BOSTON can be used immediately. Simply connect it to a power outlet and it starts operating.



ENVIRONMENT AND CLIMATE

BOSTON is completely CFC and FFC-free and uses the ecologically harmless and natural refrigerant propane (R290). They are therefore particularly environmentally friendly.



RETAIL AND STORAGE SPACE

BOSTON offers space for 22 pans of 5 liters each. In addition, another 22 pans can be stowed on a second level.

INDIVIDUELLES BRANDING

AHT cooling units are constructed individually: Using our template, you create the design, then we apply it directly during production.



TEMPERATURE RANGES

Freezing

-12°C to -23°C

USPs

EXCELLENT PRODUCT PRESENTATION

The illuminated glass dome is a real customer magnet. The sales figures are maximized through the optimal product presentation of the scooping ice cream.

EASY ACCESSIBILITY

BOSTON is optimally accessible for the sales staff. This makes serving ice cream convenient and easy.



ACCESORIES

- _ Bumper strips available in different colors
- _ Water protection strips prevent dust and water from penetrating under the devices

BOSTON

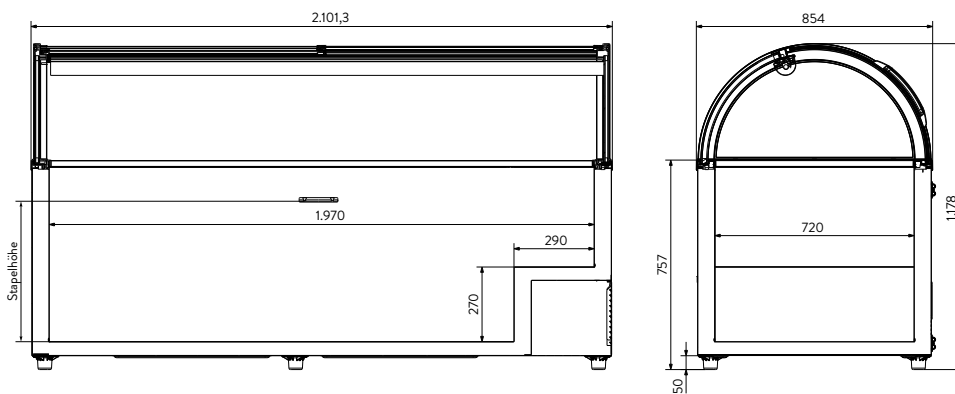

DIMENSIONS

BOSTON		210	
length, exterior / interior	mm	2,101 / 1,968	
Depth, exterior / interior	mm	854 / 718	
Height, front / rear	mm	1,178 / 1,178	
Stack height	mm	540	

Subject to technical changes; errors and omissions excepted. Version: 05/2023

AHT
a member of **DAIKIN** group

AHT Cooling Systems GmbH
Werksgasse 57
8786 Rottenmann | Austria
p. +43 3614 24 51-0
sales@aht.at
www.aht.at

FIXWELL

www.fixwell.co.nz

Fixwell Display System NZ Ltd

Level 17 SPACES, 15 Customs Street West, PWC Tower,
Commercial Bay,
Auckland, 1010, New Zealand

tel.: +64 9 970 1019

e-mail: sales@fixwell.co.nz